

Eccentric Screw Pumps

Series AE1E, AE2E

Design ID

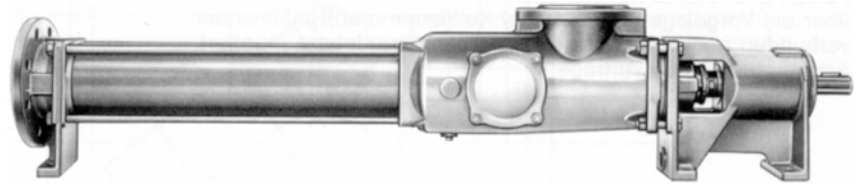

Application

For handling liquid to highly viscous, neutral or aggressive, uncontaminated or abrasive liquids, liquids containing gases or which tend to froth, also containing fibres and solid matter.

In waste water and waste water treatment engineering, chemical and petrochemical industry, paper and cellulose industry, soap and fats industry, paint and lacquer industry, food and beverage industry, plastics industry, ceramics industry, agriculture, sugar industry and in shipbuilding.

Function

Self-priming, single or two-stage, rotary positive displacement pump. Conveying elements are the rotating eccentric screw (rotor) and the fixed stator. In the cross-sectional plane, both are in contact with one another at two points forming two sealing lines along the length of the conveying elements. The contents of the sealed chambers which are formed as the rotor turns are displaced axially and with complete continuity from the suction to the delivery end of the pump. Despite rotor rotation, there is no turbulence. The constant chamber volume excludes squeezing, thus ensuring an extremely gentle low-pulsating delivery.

Structural design

By external casing connecting screws (clamping screws), the pressure casing, stator and suction casing are interconnected. The suction casings are designed particularly favourable to flow. The pump sizes 200 to 9500 in cast iron design are provided with staggered holes for cleaning. The sizes between 50 and 1000 will be supplied in a cast iron finish as an alternative with an suction casing with a square intake controller. The stator vulcanized into a tube or shell casing (even elastomer wall thickness) is provided with external collars vulcanized to it on both sides reliably sealing towards the suction casing and delivery casing and protecting the stator shell from corrosion.

Stators are supplied:

with uneven wall thickness:

single-stage for all sizes

two-stage not for sizes 550, 1000, 5000, 9500

with even wall thickness:

single-stage not for sizes 50, 550, 1000, 9500

two-stage only for sizes 100, 200, 380, 750, 1450

The exchangeable shaft sealing housing or mechanical seal housing (subsequent conversion to another sealing variant is possible) are arranged between the suction casing and bearing bracket. The sealing housings (shaft seals) are easily accessible as the complete bearing unit can be withdrawn from the driving shaft without any further pump dismounting.

Bearing of the driving spindle is effected in the bearing bracket. The torque of the drive is transmitted over the driving shaft and the joint shaft onto the rotor. On both sides, the joint shaft ends in liquid-tight encapsulated bolt joints, which are designed particularly simple and sturdy properly taking the eccentric movement of the rotor.

Shaft seal

By uncooled, cooled or heated stuffing box or by uncooled or cooled maintenance-free unbalanced, single or double-acting mechanical seal.

Material pairing and design are adapted to the respective operating conditions. For further data, refer to pages 4, 5.

The stuffing box or mechanical seal housings of the various shaft sealing types are interchangeable within one size. The various mechanical seal housing parts form a modular construction system and, in case of conversion to a different mechanical seal design, can be easily combined with one another.

Installation spaces for mechanical seals according to DIN 24 960 (except for double mechanical seal).

For further data, refer to pages 4, 5, 6 and 7.

Technical data

Deliveries, admissible speed ranges and required drive powers are to be taken from the performance graph on page 3 and/or the separate individual characteristic curves.

				AE1E	AE2E
Delivery	Q	l/min	up to	7500	2900
Temperature of fluid pumped	t	°C ①	up to	150	
Delivery pressure					
single-stage	Δp	bar ④	up to	6 ②	-
two-stage	Δp	bar ④	up to	-	10
Pump outlet pressure	p_d	bar ⑤	up to	16	
Attainable under pressure	p_s	bar	up to	0,95	
Viscosity	η	mPas	up to	300.000	
Admissible solids content	Vol% ③		up to	60	
Dry substance content	Vol% ⑥			12	

The mentioned performance data are to be considered as a product and performance abstract only. The particular operating limits can be taken from the quotation or order acknowledgement.

Max. admissible grain sizes and fiber lengths

Size	50	100	200	380	550	750	
max. grain size	mm	3	3,8	5	6,8	6,8	9,5
max. fibre length	mm	42	48	60	79	79	98

Size	1000	1450	2700	5000	9500	
max. grain size	mm	9,5	14	20	25	30
max. fibre length	mm	98	130	210	250	250

Increasing solids content and increasing grain size require a reduction of the pump speed:

- ① depending upon the fluid to be pumped and the elastomers employed.
- ② 10 bar for stator with even elastomer wall thickness.
- ③ depending upon the pump size/design, speed, fluid to be pumped.
- ④ 6 bar for shaft with shaft sleeve.
- ⑤ depending on direction of rotation, inlet pressure.
- ⑥ For suction casing with a square intake controller and worm screw on the articulated shaft.

Drive

Driving possibilities see page 13.

Drives of any manufacturers can be employed. For the technical data and dimensions, please refer to the documents of the manufacturers.

Installation

AE pumps may be installed horizontally or vertically. In case of vertical arrangement, "shaft shank downwards" is not admissible.

By means of a flexible coupling or via a gear (as a rule, V-belt drive), the pump and drive are connected with one another and mounted on a common base plate. For aggregate dimensions, please inquire.

Performance graph

For a rough selection of the pump size and speed as a function of the requested delivery and kind of fluid to be pumped. $v_{g,m}$ = available, mean sliding speed of the rotor in the stator.

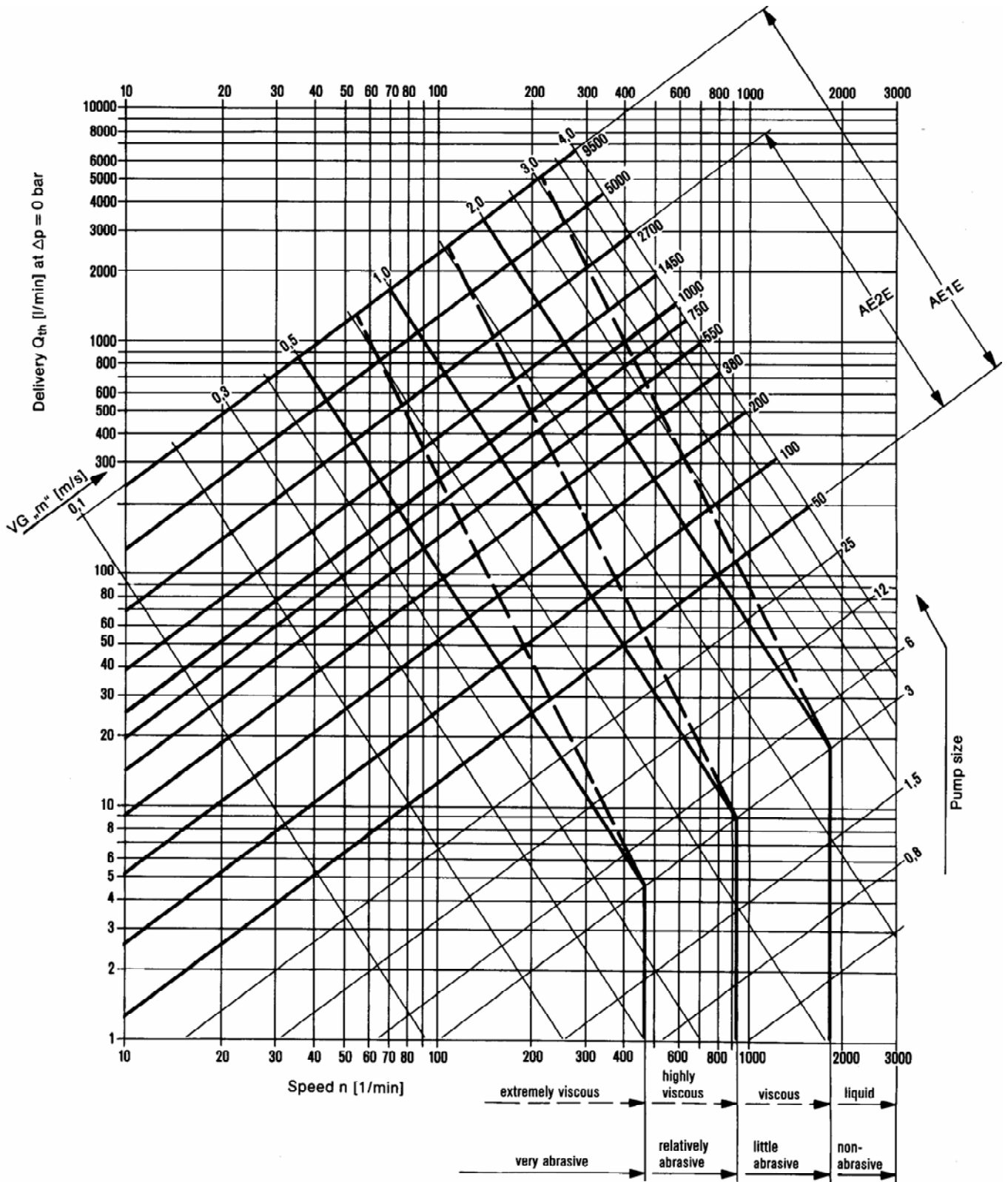

Sizes of series AE1E, AE2E. Data on the performance range not covered by AE series are to be taken from the rear side of this brochure and/or the individual brochures of the other series.

For exact performance data, please refer to the individual characteristics.

Type code

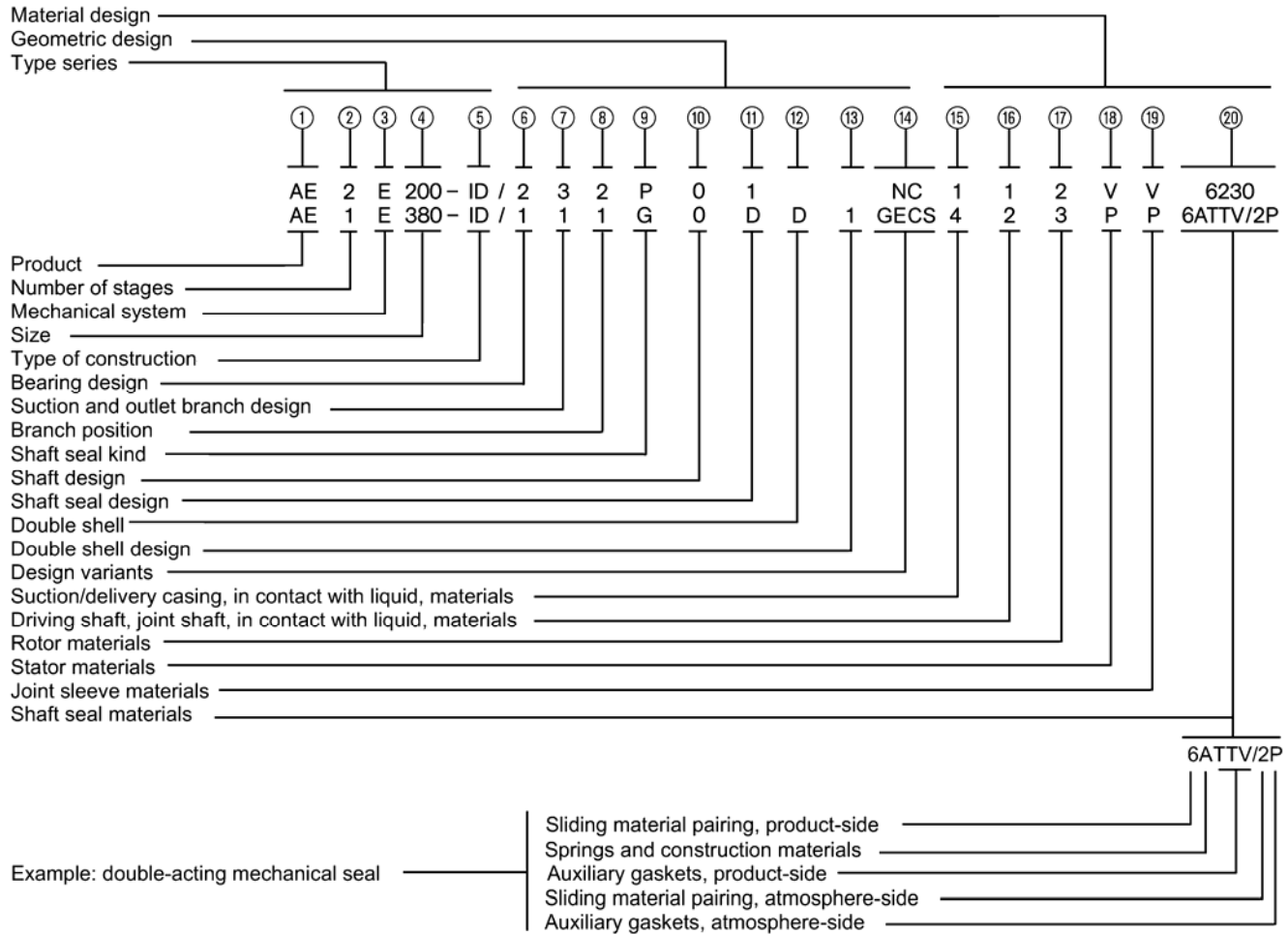

Explanations to the type code:

Position in type code	Designation	Design
①	Product	ALLWEILER eccentric screw pump
②	Number of stages:	1 = single-stage up to delivery pressure Δp 6 bar (sizes 50 to 9500) (Δp 10 bar for stator with even elastomer wall thickness) 2 = two-stage up to $\Delta p = 10$ bar (sizes 550, 1000, 5000, 9500 are available only single-stage)
③	Mechanical system	E = rated for delivery pressure Δp 10 bar (Δp 6 bar for shaft sleeve and for sizes 550, 1000)
④	Size	Possible sizes series: 50, 100, 200, 380, 550, 750, 1000, 1450, 2700, 5000, 9500 The numbers indicate the theoretic delivery in l/min with $n = 400$ 1/min and $\Delta p = 0$ bar.
⑤	Design	ID = Industrial design with internal bearing
⑥	Bearing design	1 = Hose-proof, radial bearing drive-side with sealing washer, axial bearing pump-side with shaft seal ring. Both bearings regreasable. For horizontal installation. 2 = Hose-proof, radial bearing on both sides with sealing washer, axial bearing pump-side with shaft seal-ring. Axial bearing regreasable, radial bearing lifetime-lubricated. For vertical installation with shaft shank upwards.
⑦	Suction and outlet branch design	1 = DIN-flanges 3 = ANSI-flanges X = Suction and/or delivery branch of special design } according to dimensional sheet, pages 9, 10
⑧	Branch position	1, 2, 3, 4 For the arrangement, please refer to the representation, page 9. Arrangement 3 for size 50 not possible.
⑨	Shaft seal type	P = Stuffing box or other non-mechanical shaft seal G = Mechanical seal (mechanical shaft seal)
⑩	Shaft design	0 = Shaft without shaft sleeve 1 = Shaft with shaft sleeve (not possible with pump size 50)
⑪	Shaft seal design	Stuffing boxes P01/P11 = Stuffing box of normal design (without sealing chamber ring / without flushing ring) P02/P12 = Stuffing box with flushing ring P03/P13 = Stuffing box with internal sealing chamber ring P04/P14 = Stuffing box with external sealing chamber ring P0X/P1X = Non-mechanical shaft seal of special design

⑪	Shaft seal design (continued) X = design possible	Mechanical seals:														
		for pump sizes	50	100	200	380	550	750	1000	1450	2700	5000	950			
		Shaft diameter at the location of the shaft seal	25	30	35	43	43	53	53	60	75	90	110			
		G0K/G1K = individual mechanical seal, DIN 24 960, design K, shape U	①X	X	X	X	X	X	X	X	X	X	②			
		G0N/G1N = as above, however design N	①X	X	X	X	X	X	X	X	X	X	-			
		G0S/G1S = individual mechanical seal, DIN 24 960, design K, shape U, rotating part with integrated locking device and pump-sided throttling ring	①X	X	X	X	X	X	X	X	X	X	②			
		G0T/G1T = as above, however design N	①X	X	X	X	X	-	-	X	X	-	-			
		G0Q/G1Q = individual mechanical seal, DIN 24 960, design K, shape U with quench	①X	X	X	X	X	X	X	X	X	X	②			
		G0D/G1D = double mechanical seal	①②	②	②	②	②	②	②	②	②	②	②			
		G0X/G1X = mechanical seal of special design														
① not available with shaft sleeve ② for gasket design, please inquire																
⑫	Double shell	D = Double shell for heating/cooling, available in stainless steel only. Connections as threaded nipples for liquid media. Maximum heating/cooling pressure 6 bar, maximum heating temperature + 150°C, maximum cooling temperature -40°C														
⑬	Double shell design	1 = Suction casing with double shell 2 = Stuffing box for P01/P11 with double shell 12 = Suction and shaft sealing housing P01/P11 with double shell X = Special design for other double shells														
⑭	Design variants	Stator with uneven elastomer wall thickness (all qualities)					Stator with even elastomer wall thickness (all qualities)									
		N M H T	Rotor with temperature play as a function of the temperature of the fluid pumped				D E F R	Rotor with temperature play as a function of the temperature of the fluid pumped								
		J	=	Rotor hollow	S	=	Worm on joint shaft	W	=	Winding protection on joint shaft	G	=	Stator with even elastomer wall thickness	X	=	Other designs
		C	=	Rotor hard chromium-plated	Y	=	Rotor ductile hard chromium-plated	Z	=	Rotor metallically coated						
⑮	Suction and delivery casing in contact with fluid, materials	1	=	grey cast iron EN-GJL-250	3	=	grey cast iron EN-GJL-250, inside H-rubberized	4	=	1.4408	A	=	1.4462	X	=	Special materials
⑯	Driving shaft, joint shaft in contact with liquid, materials	1	=	1.4021/1.4571	2	=	1.4301/1.4571	4	=	1.4571	A	=	1.4462	X	=	Special materials, e.g. also for joint parts
⑰	Rotor materials	2	=	1.4301/1.4308	4	=	1.4571/1.4408	A	=	1.4462						
		3	=	1.2436/1.2061/1.2379	X	=	Special materials, e.g. other metals, plastic materials									
⑱	Stator materials	WB	=	Caoutchouc soft	YL	=	Chlorosulfonated polyethylene (CSM)	P	=	Teflon glass fiber reinforced	T	=	EPDM			
		P	=	Acrylonitrile-butadiene rubbers (NBR)	V	=	Fluoroelastomer (FPM)	E	=	Special materials	X					
		PL	=	Acrylonitrile-butadiene rubbers (NBR)	HP	=	Acrylonitrile-butadiene rubbers, hydrated (HNBR)									
		N	=	Polychloroprene (N)	SL	=	Silicon bright									
		Y	=	Chlorosulfonated polyethylene (CSM)	PU	=	Polyurethan									
⑲	Joint sleeve materials	P	=	Acrylonitrile-butadiene rubbers (NBR)	Y	=	Chlorosulfonated polyethylene (CSM)	X	=	Special materials						
		PL	=	Acrylonitrile-butadiene rubbers (NBR)	V	=	Fluoroelastomer (FPM)									
		N	=	Polychloroprene (N)	B	=	Butyl caoutchouc									
⑳	Shaft seal materials	Stuffing box: 5846 = Ramie fiber with PTFE impregnation, asbestos-free 6426 = Aramid endless fibre with PTFE impregnation, asbestos-free 6230 = Graphite-incorporated PTFE with sliding agents, asbestos-free														
		Mechanical seal:														
		Sliding material pairing			Spring and constr. materials				Auxiliary gaskets							
		1st point for single gasket			2nd point				3rd point for single gasket							
		1st + 4th point for double gasket							3rd + 5th points for double gasket							
		2	=	CrMo cast iron/hard carbon	A	=	1.4300	P	=	Acrylonitrile-butadiene rubbers (NBR)	E	=	EP-caoutchouc			
		4	=	Ceramics/hard carbon	F	=	1.4571	S	=	Silicon caoutchouc	N	=	Polychloroprene (N)			
5	=	Hard metal/hard metal, highly wear-resistant	L	=	Hastelloy B	V	=	Fluoroelastomer (FPM)	TTE	=	EP-caoutchouc ①					
6	=	Silicon carbide/silicon carbide highly wear-resistant, corrosion-resistant	M	=	Hastelloy C4	TTV	=	Fluoroelastomer (FPM) ①	TTS	=	Silicon caoutchouc ①					
7	=	Silicon carbide/silicon carbide highly wear-resistant, highly corrosion-resistant	X	=	Special materials	X	=	Special materials								
X	=	Special materials									① double PTFE-coated					

Sectional drawing and component list

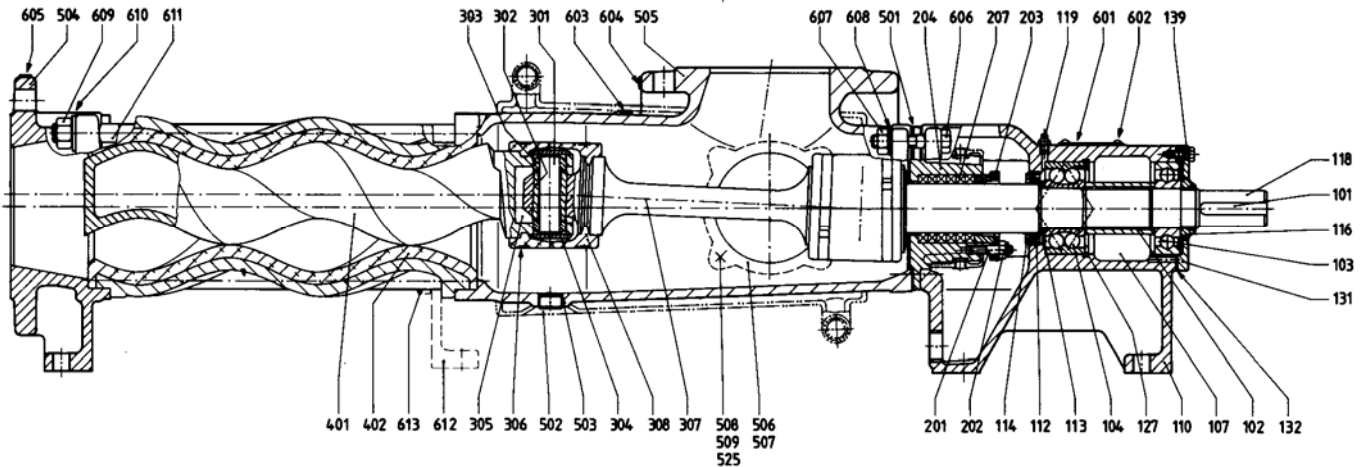

Bearing 1: Hose-proof, radial bearing drive-side with sealing washer; axial bearing pump-side with shaft seal ring. Both bearings regreasable. Only for horizontal installation.

Shaft seal P01: Due to particularly great packing length, versatile, admissible pressure at the shaft seal $p = -0,7$ to 16 bar.

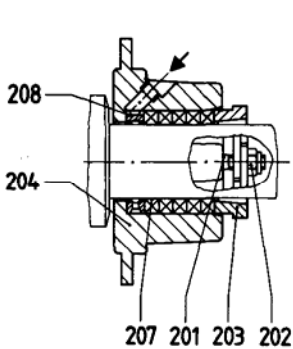

P0 Stuffing box with flushing ring
To be employed for very abrasive fluids pumped with external flushing
 $p = -0,7$ to 12 bar

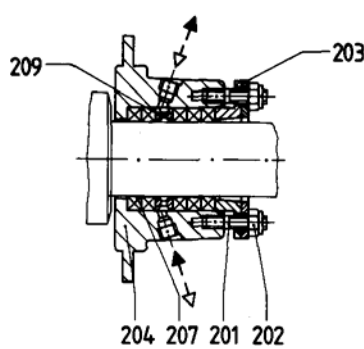

P03 Stuffing box with internal sealing chamber ring
To be employed for pure fluids with internal sealing or for abrasive fluids with external sealing
 $p = -0,8$ to 6,0 bar

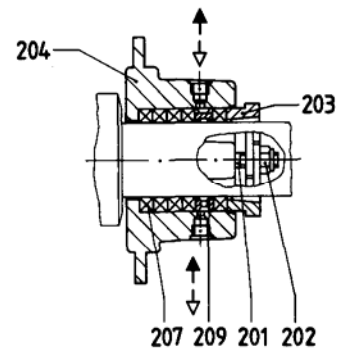

P04 Stuffing box with internal sealing chamber ring
To be employed in case of incompatibility of the external sealing liquid with the fluid pumped or if air inlet is to be avoided
 $p = -0,9$ to 12 bar

Part No.	Denomination
101	Key
102	Spacer sleeve
103	Groove ball bearing
104	Angular contact ball bearing
107	Bearing grease
110	Bearing bracket
112	Shaft seal ring
113	Spacer ring
114	Thrower
115	O-ring
116	Bearing nut
118	Driving shaft
119	Lubricating nipple

Part No.	Denomination
127	Circlip
129	Shim ring
131	Bearing cover
132	Gasket
139	Hexagon screw
201	Stud bolt
202	Self-locking nut
203	Gland half
204	Shaft sealing housing
206	Shaft sleeve
207	Stuffing box
208	Flushing ring
209	Sealing chamber ring

Part No.	Denomination
212	Screw plug
213	Joint tape
214	Mechanical seal housing
215	Mechanical seal cover
218	O-ring
219	Mechanical seal
220	Locking pin
232	Shaft seal ring
234	Throttling ring
235	O-ring
236	Locking pin
245	Hexagon screw
251	Sealing compound

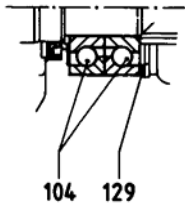

Bearing 1 for size 1450 and above
and **2:** Axial bearing with two-single-row angular contact ball bearings

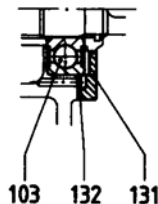

Radial bearing in case of bearing **2**
(only for vertical installation with shaft shank upwards)

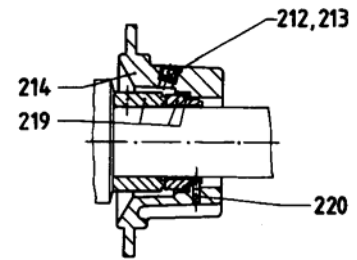

G0K/G0N Single mechanical seal, DIN 24960, K/N design, U shape. For employment, please inquire. $p = -0.5$ to 16 bar

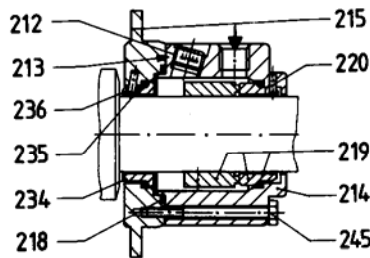

G0S/G0T Single mechanical seal, DIN 24 960, K/N design, U shape, rotating part with integrated locking device, with flushing liquid connection and pump-side throttling ring. For employment, please inquire, $p = -0.5$ to 16 bar

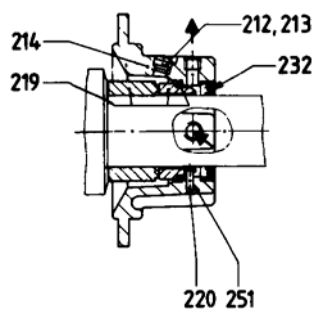

G0Q Single mechanical seal, DIN 24 960, K design, U shape, with quench. For employment, please inquire, $p = -0.5$ to 16 bar

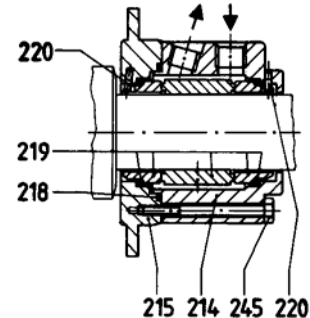

G0D Double mechanical seal, with sealing liquid connection. For employment, please inquire, $p = -0.95$ to 16 bar

Part No.	Denomination
301	Joint bolt
302	Joint bush
303	Bush for joint bolt
304	Joint sleeve
305	Joint lubricant
306	Joint clamp
307	Joint shaft
308	Joint collar
401	Rotor
402	Stator
403	Stator gasket delivery-side
404	Stator gasket suction-side
501	Gasket for suction casing

Part No.	Denomination
502	Screw plug
503	Joint tape
504	Delivery casing
505	Suction casing
506	Suction casing cover
507	Gasket
508	Stud bolt
509	Hexagon nut
510	Fan-type lock washer
525	Washer
601	Type plate
602	Round head grooved pin
603	Information plate commissioning

Part No.	Denomination
604	Information plate suction
605	Information plate pressure
606	Hexagon screw/stud bolt
607	Hexagon nut
608	Fan-type lock washer
609	Hexagon nut
610	Washer
611	Clamp bolt
612	Support
613	Hexagon screw
627	Information plate physical hazard

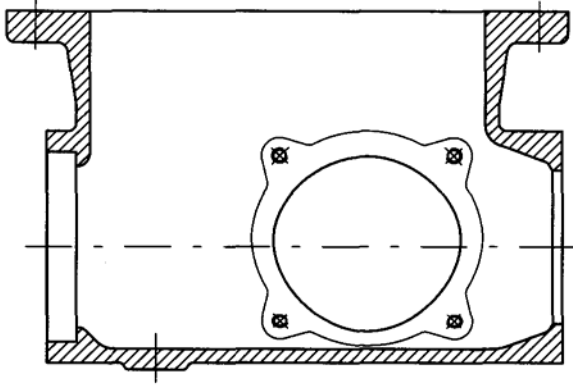

Suction casing with a square intake controller

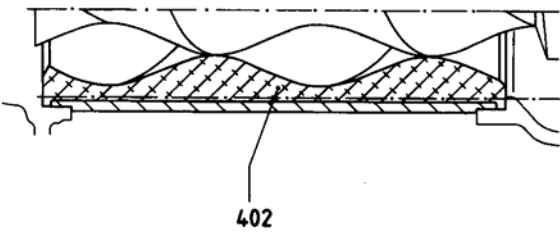

Stator with uneven elastomer wall thickness

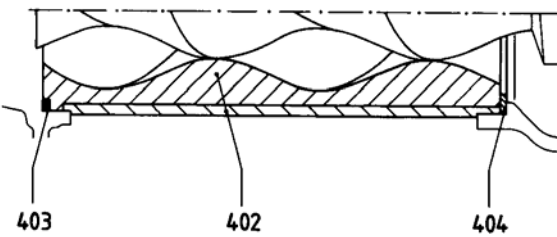

Stator of plastic material

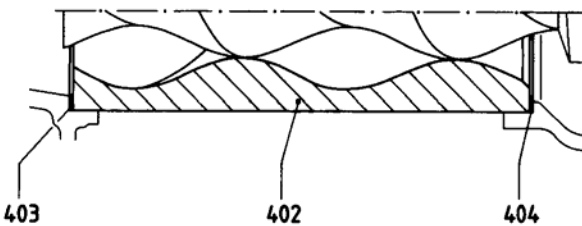

Stator of metal

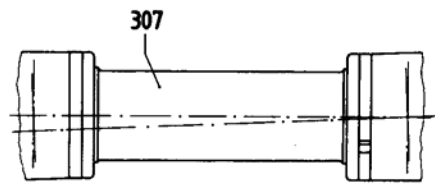

Winding protection on joint shaft

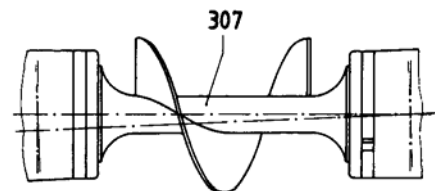

Worm on joint shaft

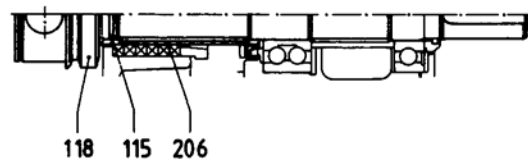

Shaft with shaft sleeve from size 100 and above for all gasket designs possible

Pump dimensions, auxiliary connections, possible branch positions, weights

Suction casing with flange connection

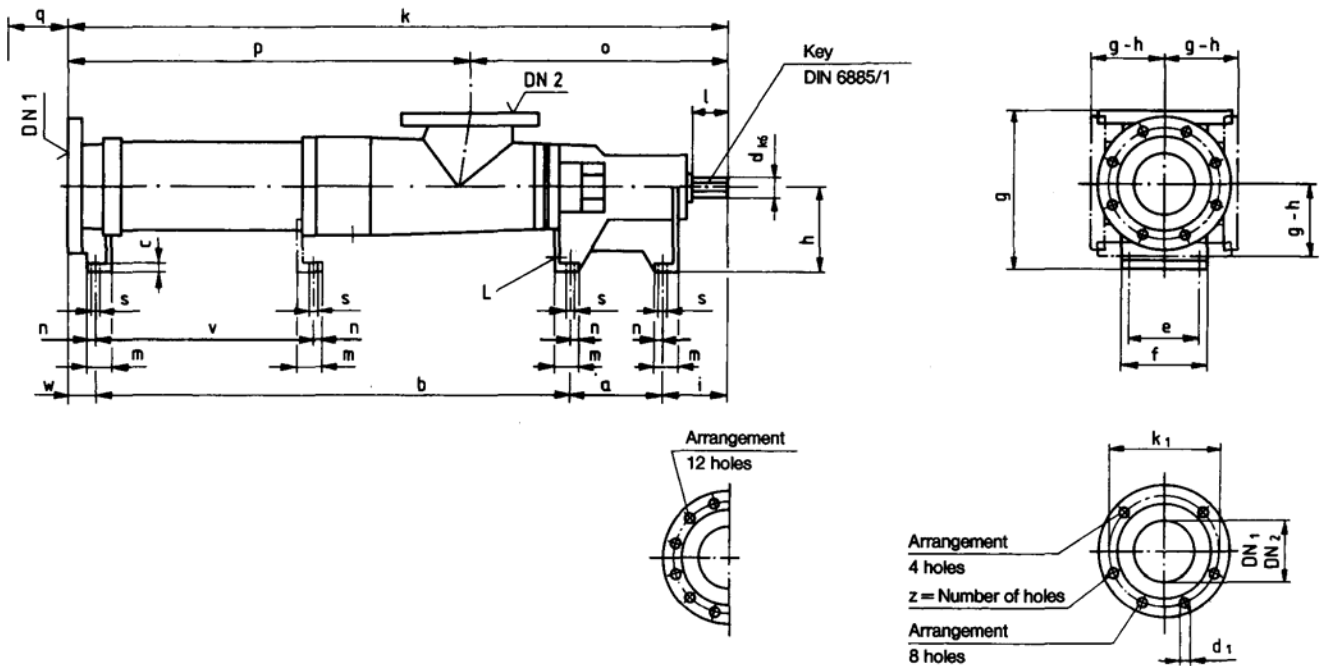

Dimensions in mm, nominal widths of ANSI flanges (DN) in inch. Subject to alternations.

Sense of rotation: normally counterclockwise as seen from the driving side, here DN₁ = outlet branch, DN₂ = suction branch, change of sense of rotation possible, then, DN₁ = suction branch, DN₂ = outlet branch

Series Size	Pump dimensions																	Max. mass kg
	a	b	c	d	e	f	h	i	l	m	n	o	① q	s	L	v		
AE1E 50-ID	114	425	10	18	75	95	90	65	30	30	11	278	165	9	Rp 3/8	-	24	
AE2E 50-ID		585											280					28
AE1E 100-ID	122	511	10	22	85	115	100	79	40	30	11	316	205	9	Rp 3/8	-	34	
AE2E 100-ID		711											365					28
AE1E 200-ID	140	645	13	28	100	125	125	95	50	38	13	378	270	11,5	Rp 1/2	-	53	
AE2E 200-ID		897											470					28
AE1E 380-ID	151	769	15	32	114	140	140	106	60	40	14	422	330	14	Rp 3/4	-	71	
AE2E 380-ID		1075											580					28
AE1E 550-ID	151	923	15	32	114	140	140	106	60	40	14	422	430	14	Rp 3/4	-	85	
AE1E 750-ID	171	959	16	42	132	168	160	118	65	50	19	492	420	18	Rp 3/4	-	113	
AE2E 750-ID		1359											780					28
AE1E 1000-ID	171	1071	16	42	132	168	160	118	65	50	19	492	490	18	Rp 3/4	-	132	
AE1E 1450-ID	190	1174	16	48	164	200	180	130	75	50	19	546	510	18	Rp 3/4	-	210	
AE2E 1450-ID		1679											980					28
AE1E 2700-ID	220	1430	21	60	200	245	225	158	90	63	23	669	620	22	Rp 1	-	290	
AE2E 2700-ID		2088											1240					28
AE1E 5000-ID	266	1773	24	75	245	290	250	182	110	65	23	792	780	22	Rp 1	-	570	
AE1E 9500-ID	320	2219	29	95	290	350	280	215	130	80	30	947	1000	27	Rp 1	1092	937	

① Stator dismantling dimension

Possible branch positions as seen from the drive

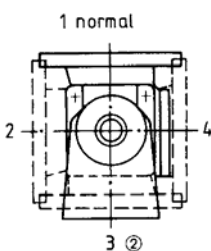

② for size 25 not possible

Flange dimensions

DIN 2501, PN 16 ③				ANSI B 16.1/16.5, Class 125/150 ④			
DN ₁ / DN ₂	k ₁	d ₁	z	DN ₁ / DN ₂	k ₁	d ₁	z
50	125	18	4	2	120,6	19	4
65	145	18	4	2 1/2	139,7	19	4
80	160	18	8	3	152,4	19	4
100	180	18	8	4	190,5	19	8
125	210	18	8	5	215,9	22,2	8
150	240	22	8	6	241,3	22,2	8
200	295	22	12	8	298,4	22,2	8
250	355	26	12	10	361,9	25,4	12
300	410	26	12	12	431,8	25,4	12

Series Size	Companion dimensions for suction and outlet branch																	
	Flanges DIN 2501, PN 16						Flanges ANSI B16.1, Class 125 ④						Flanges ANSI B16.5, Class 150 ④					
	⑤ DN ₁	⑤ DN ₂	③ k	③ p	③ w	③ g	DN ₁	DN ₂	③ k	③ p	③ w	③ g	DN ₁	DN ₂	k	p	w	g
AE1E 50-ID AE2E 50-ID	50	50	647 807	369 529	43	175	2	2	643 803	365 525	39	171	2	2	647 807	369 522	43	175
AE1E 100-ID AE2E 100-ID	65	65	758 958	442 642	46	190	2 ½	2 ½	757 957	441 641	45	189	2 ½	2 ½	762 962	446 646	50	194
AE1E 200-ID AE2E 200-ID	80	80	925 1177	547 799	45	230	3	3	923 1175	545 797	43	228	3	3	928 1180	550 802	48	233
AE1E 380-ID AE2E 380-ID	100	100	1070 1376	648 954	44	260	4	4	1072 1378	650 956	46	262	4	4	1072 1378	650 956	46	262
AE1E 550-ID	100	100	1224	802	44	260	4	4	1226	804	46	262	4	4	1226	804	46	262
AE1E 750-ID AE2E 750-ID	125	125	1292 1692	800 1200	44	300	5	5	1292 1692	800 1200	44	300	5	5	1292 1692	800 1200	44	300
AE1E 1000-ID	125	125	1404	0912	44	300	5	5	1404	0912	44	300	5	5	1404	912	44	300
AE1E 1450-ID AE2E 1450-ID	150	150	1553 2058	1007 1512	59	350	6	6	1553 2058	1007 1512	59	350	6	6	1553 2058	1007 1512	59	350
AE1E 2700-ID AE2E 2700-ID	200	200	1872 2530	1203 1861	64	425	8	8	1872 2530	1203 1861	64	425	8	8	1872 2530	1203 1861	64	425
AE1E 5000-ID	250	250	2301	1509	80	485	10	10	2301	1509	80	485	10	10	2301	1509	80	485
AE1E 9500-ID	300	300	2827	1880	73	560	12	12	2827	1880	73	560	12	12	2827	1880	73	560

③ for rubber-coating + 3 mm
④ Sealing surface: stock finish

⑤ up to DN 100 sealing surface DIN 2526 shape C, machined as shape A
from DN 125 sealing surface DIN 2526 shape A

Arrangement of auxiliary connections for shaft seals

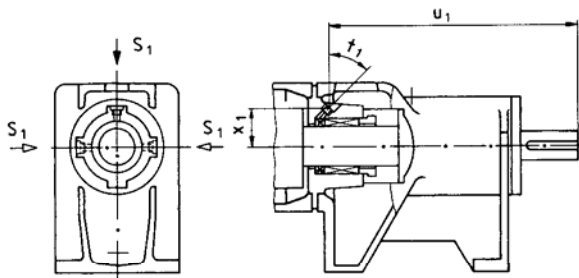

P02, P12 with flushing ring

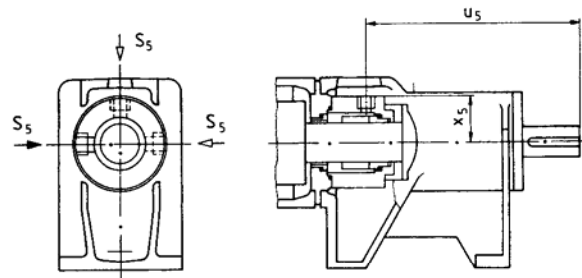

G0S/G0T, G1S/G1T with flushing connection

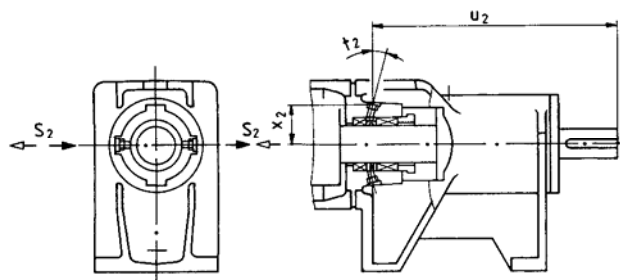

P03, P13 with internal sealing chamber ring

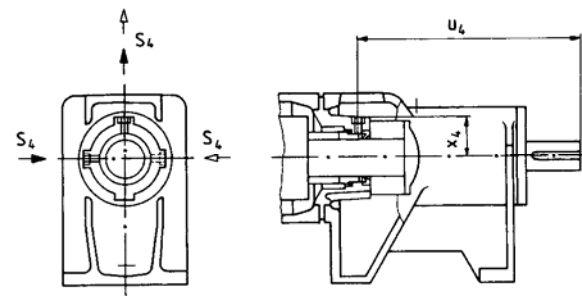

G0Q, G1Q with quench connection

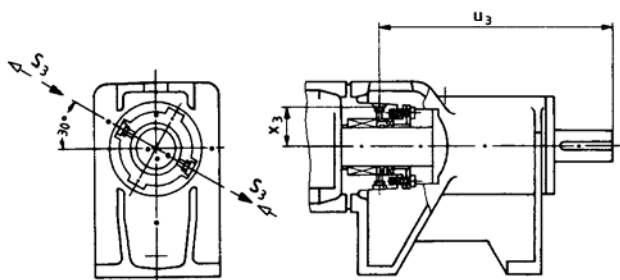

P04, P14 with external sealing chamber ring

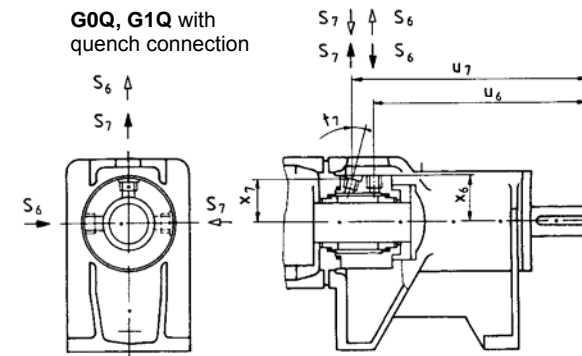

G0D, G1D with sealing connection

Series Size	Companion dimensions auxiliary connections for shaft seals											
	P02, P12 with flushing ring				P03, P13 with internal sealing chamber ring				P04, P14 with external sealing chamber ring			
	S ₁ ⊕	u ₁	x ₁	t ₁	S ₂ ⊕	u ₂	x ₂	t ₂	S ₃ ⊕	u ₃	x ₃	
AE.E 50-ID	M 8 x 1	195,5	28	42°	M 8 x 1	188	30	20°	M 8 x 1	180,5	30,5	
AE.E 100-ID	M 8 x 1	217	31,5	40°	M 8 x 1	211	32	20°	M 8 x 1	202,5	33,5	
AE.E 200-ID	Rp ½	255	38	42°	Rp ½	248	40	17°	Rp ½	236	39,5	
AE.E 380-ID	Rp ½	279	42	42°	Rp ½	272	44	17°	Rp ½	261	43,5	
AE.E 550-ID	Rp ½	316	52	42°	Rp ½	307	54	17°	Rp ½	292,5	54,5	
AE.E 750-ID	Rp ½	349	56	35°	Rp ½	338,5	57	13°	Rp ½	322,5	58	
AE.E 1000-ID	Rp ½	416	67	35°	Rp ¼	403	68,5	13°	Rp ¼	383	69,5	
AE.E 2700-ID	Rp ¼	492	77	35°	Rp ¼	474,5	79	13°	Rp ¼	451	80	
AE.E 5000-ID	Rp ¼	588	94,5	35°	Rp ¼	568,5	97	13°	Rp ¼	542	97	

Series Size	Companion dimensions auxiliary connections for shaft seals													
	G0S/G0T, G1S/G1T with flushing connection			G0Q, G1Q with quench connection			G0D, G1D with sealing connection							
	S ₅ ⊕	u ₅	x ₅	S ₄ ⊕	u ₄	x ₄	S ₆ ⊕	S ₇ ⊕	u ₆	u ₇	x ₆	x ₇	t ₇	
AE.E 50-ID	Rp ¼	157	34	Rp ½	167	30,5	Rp ¼	Rp ¼	157	182,5	34	33	15°	
AE.E 100-ID	Rp ¼	179	38	Rp ½	187,5	30,5	Rp ¼	Rp ¼	179	204,5	38	36,5	15°	
AE.E 200-ID	Rp ¼	220,5	41,5	Rp ½	230	33,5	Rp ¼	Rp ¼	220,5	245,5	41,5	40	15°	
AE.E 380-ID	Rp ¾	241	48,5	Rp ¾	255	41	Rp ¾	Rp ¾	241	266	48,5	47	15°	
AE.E 550-ID	Rp ¾	280	56	Rp ¾	287	54	Rp ¾	Rp ¾	280	305,5	56	53,5	20°	
AE.E 750-ID	Rp ¾	297	61	Rp ¾	315,5	57,5	Rp ¾	Rp ¾	297	337,5	61	58,5	20°	
AE.E 1000-ID	Rp ¾	364	71,5	Rp ¼	375,5	68,5	Rp ¾	Rp ¾	364	406	71,5	69	22°	
AE.E 2700-ID	Rp ¾	440,5	81	Rp ¼	446	79	Rp ¾	Rp ¾	440,5	479,5	81	78,5	20°	
AE.E 5000-ID	Rp ¾	527	98	Rp ¾	542	96	Rp ¾	Rp ¾	527	576	98	95,5	25°	

⊕ Screw hole DIN 3852, shape Z

▶ Standard supply

▷ Possible supply, for these purposes, the sealing housing must be turned in case of designs P02/P12, G0S/G1S, G0T/G1T, G0Q/G1Q, G0D/G1D.

Pump dimensions auxiliary connections, possible branch positions, weights
Suction casing with a square intake controller

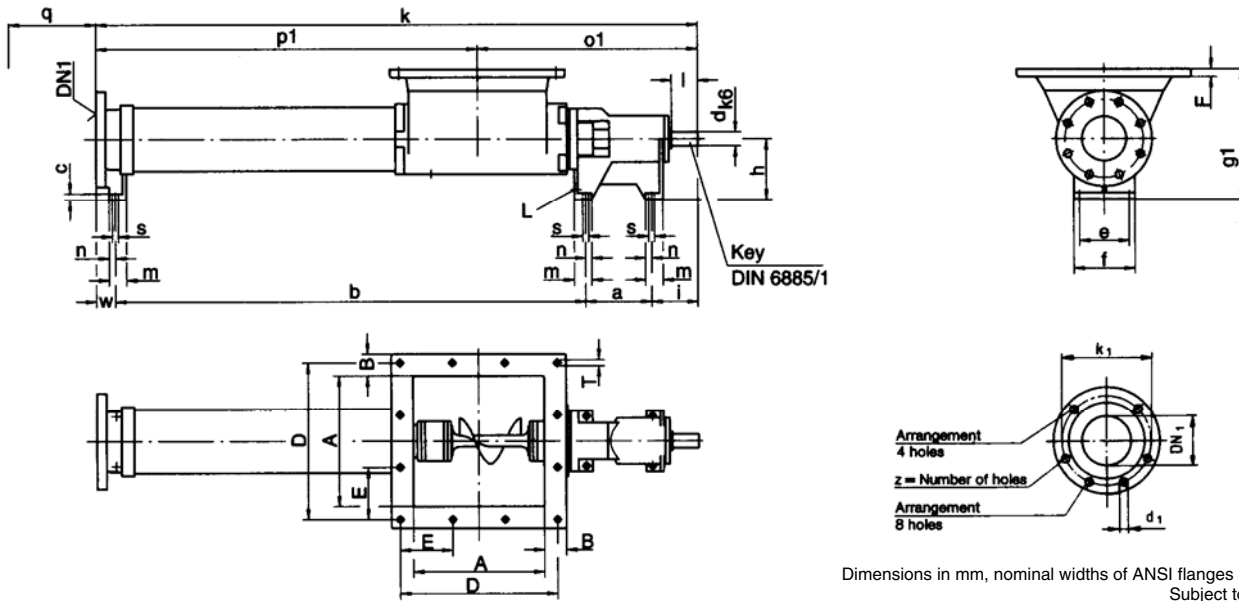

Dimensions in mm, nominal widths of ANSI flanges (DN) in inch.
Subject to alterations.
Sense of rotation: normally counterclockwise as seen from the driving side.

Series Size	Pump dimensions																Max. mass kg
	a	b	c	d	e	f	② g ₁	h	i	l	m	n	o ₁	① q	s	L	
AE1E 50-ID																	28
AE2E 50-ID	114	425	10	18	75	95	200	90	65	30	30	11	327	165	9	Rp ⅝	32
AE1E 100-ID																	39
AE2E 100-ID	122	511	10	22	85	105	220	100	79	40	30	11	370	205	9	Rp ⅝	47
AE1E 200-ID																	61
AE2E 200-ID	140	645	13	28	100	125	260	125	95	50	38	13	447	270	11,5	Rp ½	73
AE1E 380-ID																	82
AE2E 380-ID	151	769	15	32	114	140	300	140	106	60	40	14	504	330	14	Rp ¾	103
AE1E 550-ID																	95
AE2E 550-ID	151	923	15	32	114	140	300	140	106	60	40	14	504	430	14	Rp ¾	130
AE1E 750-ID																	174
AE2E 750-ID	171	959	16	42	132	168	340	160	118	65	50	19	588	420	18	Rp ¾	174
AE1E 1000-ID																	149
AE2E 1000-ID	171	1071	16	42	132	168	340	160	118	65	50	19	588	490	18	Rp ¾	149

Series Size	Companion dimensions intake controller							Companion dimensions outlet branch							
	A	B	D	E	F	T	DIN 2501, PN 16 ④				ANSI B16.1, Class 125 ③				
							DN ₁	k ₂	p ₁ ②	w ₂	DN ₁	k ₂	p ₁ ②	w ₂	
AE1E 50-ID	160	40	210	70	16	12	50	647	320	43	2	643	316	39	
AE2E 50-ID								807	480			803	476		
AE1E 100-ID	200	42	255	85	16	12	65	758	388	46	2 ½	757	387	45	
AE2E 100-ID								958	588			957	587		
AE1E 200-ID	250	50	315	105	18	14	80	925	478	45	3	923	476	43	
AE2E 200-ID								1177	730			1175	728		
AE1E 380-ID	300	50	360	120	18	14	100	1070	566	44	4	1072	568	46	
AE2E 380-ID								1376	872			1378	874		
AE1E 550-ID	300	50	360	120	18	14	100	1224	720	44	4	1226	722	46	
AE1E 750-ID	350	50	414	138	20	14	125	1292	704	44	5	1292	704	44	
AE2E 750-ID								1692	1104			1692	1104		
AE1E 1000-ID	350	50	414	138	20	14	125	1404	816	44	5	1404	816	44	

- ① Stator dismantling dimension
- ② for rubber-coating + 3 mm
- ③ sealing surface: stock finish
- ④ up to DN 100 sealing surface DIN 2526 shape C, machined as shape A from DN 125 sealing surface DIN 2526 shape A

Possible branch positions as seen from the drive

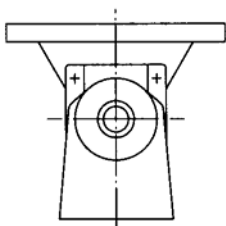

Flange dimensions							
DIN 2501, PN 16 ④				ANSI B 16.1 Class 125 ③			
DN ₁	k ₁	d ₁	z	DN ₁	k ₁	d ₁	z
50	125	18	4	2	120,6	19	4
65	145	18	4	2 ½	139,7	19	4
80	160	18	8	3	152,4	19	4
100	180	18	8	4	190,5	19	8
125	210	18	8	5	215,9	22,2	8

Driving possibilities

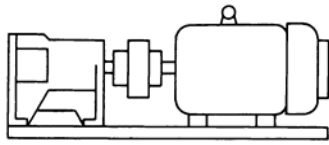

1 AE-ID with flexible coupling and motor

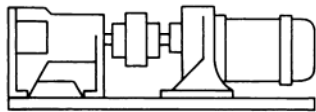

2 AE-ID with flexible coupling and geared motor

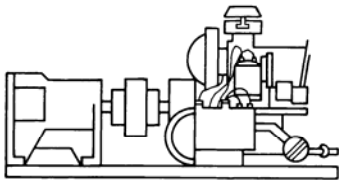

3 AE-ID with flexible coupling and combustion engine

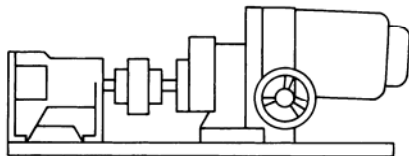

6 AE-ID with flexible coupling and infinitely variable gear

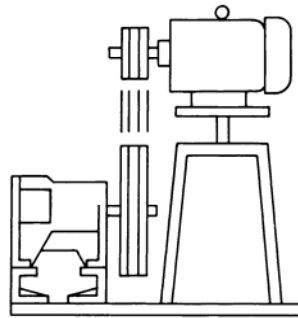

4 AE-ID with V-belt drive, rocker and motor arranged behind the pump

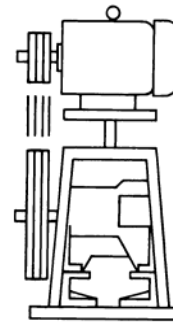

5 AE-ID with V-belt drive rocker and motor, arranged above the pump

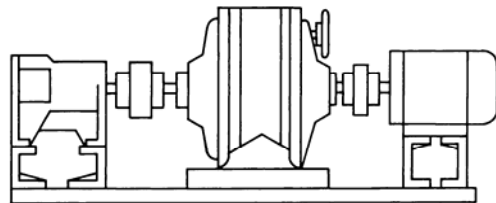

7 AE-ID with flexible coupling, gear or variable speed gear, flexible coupling and motor

Further driving variants (e.g. hydraulic or pneumatic drives) are possible.

Range of eccentric screw pumps	Series	Number of stages	Maximum output at $\Delta p = 0$ bar		Maximum delivery pressure bar	Maximum viscosity mPa s
			m ³ /h	l/min		
	AE.E-ID	1,2	450	7500	10	300.000
	AE.N-ID	1,2	290	4850	16	270.000
	AE.H-ID	2,4	174	2900	24	270.000
	AEB.E-IE	1,2	174	2900	6	300.000
	AEB.N-IE	1,2	111	1850	12	270.000
	AEB4H-IE	4	12	200	24	270.000
	AED.E-ID	1	720	12000	8	250.000
	AED.N-ID	2	450	7500	16	225.000
	AEDB.E-IE	1	258	4300	6	250.000
	AEDB.N-IE	2	174	2900	12	225.000
	AE.N...-RG	1,2,4	30	500	20	1.000.000
	TECFLOW	1	186	3100	4	200.000
	SEZP	1,2	21	350	10	1.000.000
	SNZP	1,2	45	750	12	1.000.000
	SSP	1,2	48	800	12	150.000
	SSBP	1,2	48	800	12	150.000
	SETP ①	1,2	140	2350	10	300.000
	SETBP	1,2	40	670	10	150.000
	SEFBP	1	40	670	6	150.000
	SMP	1	40	670	6	150.000
	SMP2	1	5,5	92	6	11.500
	AFP	1	2,8	47	6	50.000
	ANP	2	2,5	42	12	20.000
	ANBP	2	2,5	42	12	20.000
	ASP	2	2,5	42	12	20.000
	ASBP	2	2,5	42	12	20.000
	ADP	3	0,6	10	12	20.000
	ADBP	3	0,6	10	12	20.000
	ACNP	1,2	29	480	12	150.000
	ACNBP	1,2	29	480	12	150.000

① Special versions for higher pressures available

Peristaltic range	Series	Maximum output		Maximum delivery pressure bar	Maximum viscosity mPa s
		m ³ /h	l/min		
	ASL	2,4	40	4	100.000
	ASH	60	1000	15	100.000

Macerator range	Series	Maximum throughput	Generated delivery head
		m ³ /h	m
	AM...S-1	80 at 3% solids	3
	ABM...S-1	80 at 3% solids	3
	AM...I-1	160 at 3% solids	-
	ABM...I-1	80 at 3% solids	-

Accessories

Pump accessories: Stator setting devices, electrical heaters, bridge breakers.

Drivers: Electric motors, geared motors, variable speed transmissions, reduction gearboxes, internal combustion engines, pneumatic and hydraulic drives.

Transmission components: Couplings, V-belt transmissions, toothed belt transmissions, other types of transmission.

Base plates: Standard and special versions, wheeled trolleys, mounting flanges.

Safety arrangements: Bypass lines with safety or regulating valves, systems to guard against dry running (conductive, capacitive, thermal etc.).

Other accessories: Electrical, hydraulic and pneumatic control arrangements, filter systems, metering equipment, seal liquid and circulating systems for shaft seals, valves, flanges, flexible pipes.

Subject to technical alterations.



ALL FLUIDS. NO LIMITS.

ALLWEILER GmbH
Werk Bottrop

Postfach 200123 · 46223 Bottrop
Kirchhellener Ring 77-79 · 46244 Bottrop
Germany

Tel. +49 (0)2045 966-60
Fax +49 (0)2045 966-679
E-Mail: service-ge@allweiler.de
Internet: http://www.allweiler.com